

ES24

PIR Sensor Stair Light Controller

Sensor

Features

- Multi-function dual PIR sensor stair light controller features daylight sensor, 2 groups different SPI(TTL) signal output.
- Group 1 SPI signal output to realize white light step or color light step control.
Default is white light step control, use with ES-F step sub-controller to realize the step control of each step white light strip.
- Group 2 SPI signal output for color light flow control.
- Color light step or color light flow output, can drive 18 kinds of IC digital RGB LED strip, can set IC type and R/G/B order.
Compatible IC:
TM1804, TM1812, UCS1903, UCS1909, UCS1912, UCS2903, UCS2909, UCS2912, WS2811, WS2812, TM1829, TM1914A, GW6205, GS8206, UCS5603, UCS2603, SM16714D, SM16703P.
- Easy operation with OLED display and 3 buttons.
- Built-in multiple color mode, speed and brightness 1-8 grade adjustable.
- Use with two laser sensing heads(EL-C) for precise step sensing.



CE RoHS

Technical Parameters

ES24 master parameters		ES-F step sub-controller parameters		Safety and EMC	
Input voltage	5-24VDC	Input voltage	5-24VDC	EMC standard	EN IEC 55015 EN IEC 61547
Input current	20A	Output voltage	5-24VDC	Safety standard	EN 61347-1/-2 EN 62493
Output power	100-480W	Output current	Max1A	Certification	CE RoHS
Output type	2 x SPI(TTL)	Input signal	SPI(TTL)	Environment	
Number of steps	Default 24, Max 72	Package		Operation temperature	Ta: -30°C ~ +55°C
Stream pixel count	Max 720	Size	L192 x W153 x H55mm	Case temperature(Max.)	Tc: +85°C
Sensor data		Gross weight	1.52kg	IP rating	IP20
Sensing distance	0.05-2.5m	Warranty			
Sensitivity angle	20°	Warranty	5 years		

Mechanical Structures and Installations

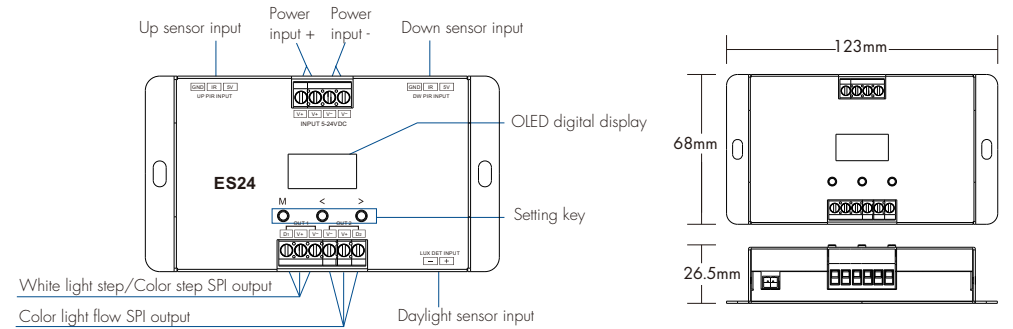

Two types of ES-F step sub-controller: dupont port and red/black wires output:

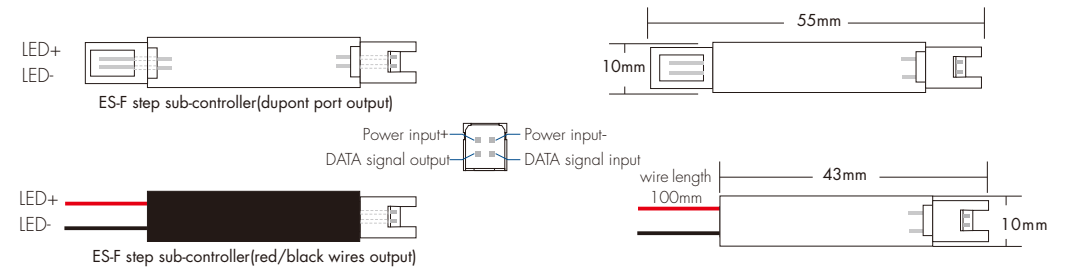

Wiring Diagram

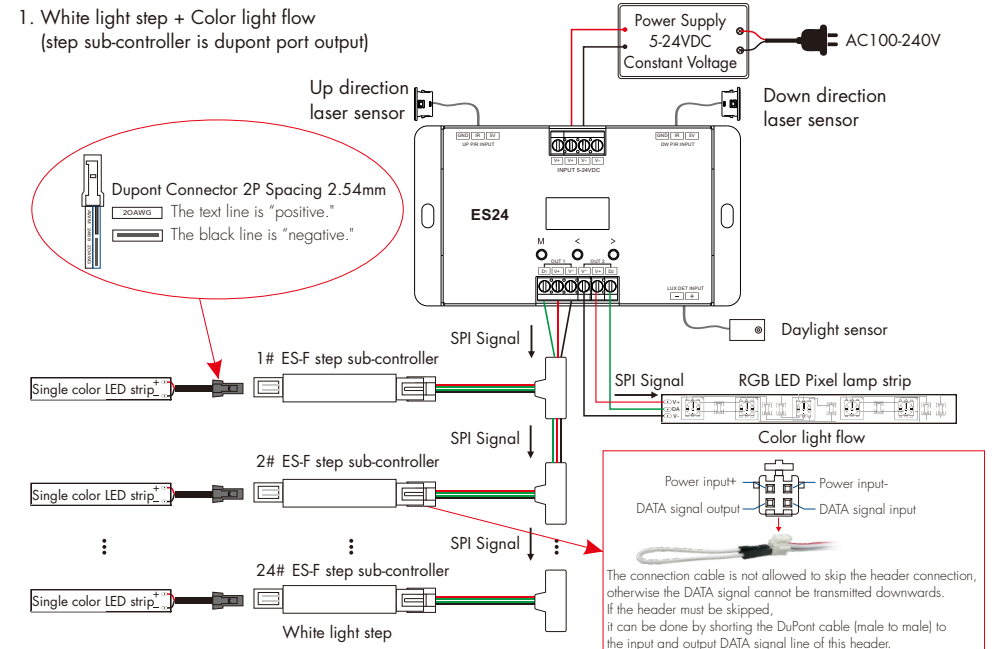

2. White light step + Color light flow
(step sub-controller is red/black wires output)

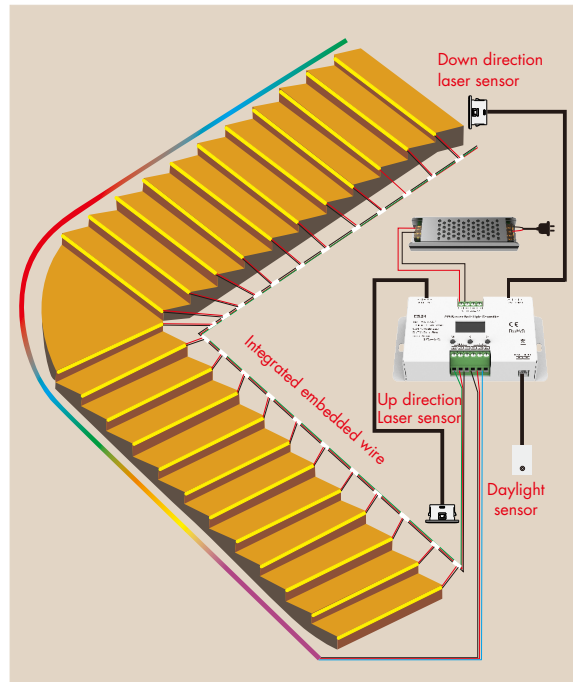
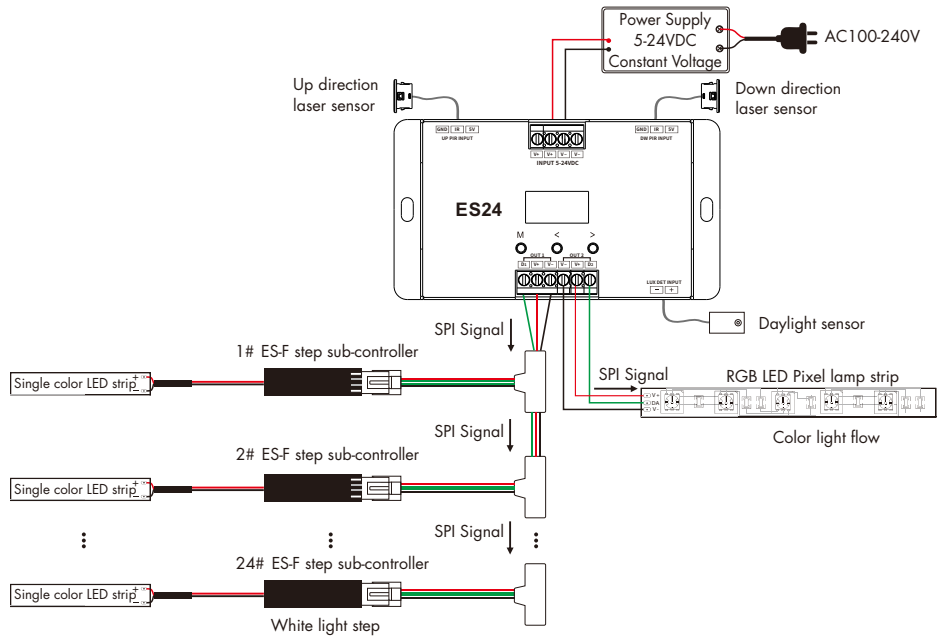

(step + flow stairs connection schematic)

Note:

1. When the SPI strip load does not exceed 20A, the same power supply can simultaneously power the ES24(WT) master and the SPI strip at the same time. When the load on the SPI strip exceeds 20A, separate power supplies are required for the ES24(WT) master and the SPI strip. Only DATA and GND signal lines are connected between ES24(WT) master and SPI strip.
2. The white light step must be used with ES-F step sub-controller and select ES-F in the system parameter interface "CH1".
3. The white light step defaults to 24 steps and comes standard with one 24-connector SPI cable. The white light step can be set up to 72 steps, which means that three 24-connector SPI connection cables are required, and connects 72 ES-F step controllers.
4. The color light step needs to select the chip type such as TM1809 in the system parameter interface "CH1".
5. The color light step defaults to 24 steps with 10 pixels per step. The maximum number of colored steps is 72, and the maximum number of pixels per step is 90.
6. The color light flow can control up to 720 pixel points of SPI strip.
7. The Up/Down sensor can be replaced with other sensors that output 5V level signal.
8. The daylight sensor must be exposed to ambient light in the control area and must not be covered by shade.

3. Color light step + Color light flow

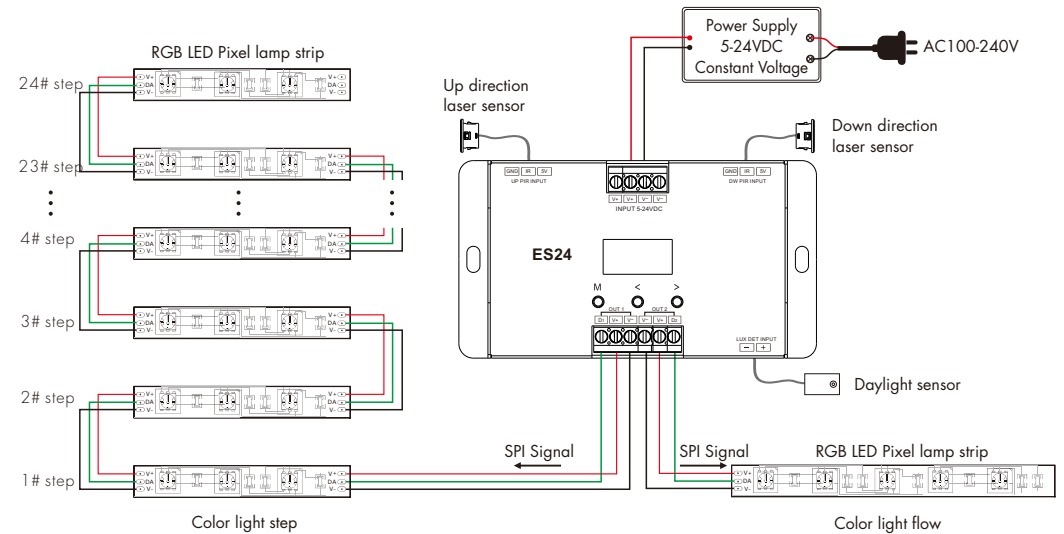

Main Interface

1. Short press M key, enter the operation parameter setting status, including step number, pixel point number, I/O, color mode, brightness and speed level.

Short press M key to switch multiple parameters, press < or > key for parameters' adjustment.

Step: Set the number of steps of white light step or color light step.

- Number of white light steps, 08-72.
- Number of color light steps, 08-72; Pixel dot number of each step, 01-90.
The Step number x Dot number must < 720.
For example, to display 24¹⁰, 24 indicates the number of steps and 10 indicates the length of pixel dots per step.

Dot: Total number pixels of color light flow, 024-720.

I/O: Turn on/off light mode, that is, sequential or simultaneous on/off light, a total of four options.
White/color light step and color light flow using the same on/off light mode.

Mode: Color mode number, 01-13,

12 Mode is user-defined static color.

13 mode is a static or dynamic mode customized by RF remote control.

Color light step and color light flow use the same mode number.

Bright: Brightness level, 1-8, 8 is the maximum brightness.

The same brightness level is used for white/color light step and color light flow.

Speed: Speed level, 1-8, 8 is the fastest speed.

The same speed level is used for white/color light step and color light flow.

Inductive on/off light methods list:

Display	Name
sIs0	Turn on and turn off lights in sequence
sIc0	Turn on the lights in sequence and turn off the lights at the same time
cIs0	Turn on the lights at the same time and turn off the lights in sequence
cIc0	Turn on and turn off lights at the same time

Color light step / Color light flow mode list:

No.	Name
01	Red
02	Orange
03	Yellow
04	Green
05	Cyan
06	Blue
07	Purple
08	White
09	Color queue (7 color + White)
10	Color chase(7 color + White)
11	Color fade (6 color flow)
12	Rxxx Gxxx Bxxx (User define)
13	RF custom

2. After finishing the setting, long press M key or wait 15s to quit parameter setting state.

```
Step:24 Dot:300
I/O:sIs0 Mode:01
Bright:8 Speed:8
Light up start
```

White light step + Color light flow
(Inductive indication on 4 line)

```
Step:2410Dot:300
I/O:sIs0 Mode:01
Bright:8 Speed:8
*****
```

Color light step + Color light flow
(Light on/off state on 4 line)

```
Dot:300
I/O:sIs0 Mode:01
Bright:8 Speed:8
*****
```

Color light flow

```
Step:2410
I/O:sIs0 Mode:01
Bright:8 Speed:8
*****
```

Color light step

```
Step:24
I/O:sIs0
Bright:8 Speed:8
*****
```

White light step

The the 4th display color mode name defaultly.

When the controller is in induction state, the indication of inductive signal input ("Light up start" and "Light down start") is displayed first, and then the light on/off status is displayed.

If the current detected LUX value is greater than daylight sensor threshold, display "Light up off" or "Light down off" on the 4 line.

When the lights are turned off with RF remote control, display "Lights off" on the 4 line.

System Parameters Setting

1. Long press M key for 2s, enter system parameters setting state, including chip type and RGB order, custom RGB color, the daylight sensor threshold, and turn off light delay time.

Short press M key to switch multiple parameters, press < or > key for parameters' adjustment.

CH1: set white light step or color light step output.

White light step output select ES-F (step sub-controller).

Color light step output select a variety of chips (TM1809, etc.),

and six RGB sequences (RGB, RBG, GRB, GBR, BRG, BGR) can be selected.

When OFF is selected, the CH1 output is turned off.

CH2: set color light flow output.

Color light flow select a variety of chips (TM1809, etc.),

and six RGB sequences (RGB, RBG, GRB, GBR, BRG, BGR) can be selected.

When OFF is selected, the CH2 output is turned off.

Note: Different chip types are available for color light step and color light flow output.

```
CH1:ES-F
CH2:TM1809 RGB
DefRGB: FF FF 80
LuxSet: OFF *050
```

White light step + Color light flow

```
CH1:TM1809 RGB
CH2:TM1809 RGB
DefRGB: FF FF 80
LuxSet: OFF *050
```

Color light step + Color light flow

```
CH1:OFF
CH2:TM1809 RGB
DefRGB: FF FF 80
LuxSet: OFF *050
```

Color light flow

```
CH1:TM1809 RGB
CH2:OFF
DefRGB: FF FF 80
LuxSet: OFF *050
```

Color light step

```
CH1:ES-F
CH2:OFF
DefRGB: FF FF 80
LuxSet: OFF *050
```

White light step

Digital pixel RGB LED strip compatible IC types list:

IC type	Compatible IC type
TM1809	TM1804, TM1812, UCS1903, UCS1909, UCS1912, UCS2903, UCS2909, UCS2912, WS2811, WS2812, SM16703P
TM1829	
TM1914A	
GW6205	
GS8206	GS8208
UCS5603	
UCS2603	
SM16714D	

Def RGB: RGB value for user-define color, with 00-FF (0-255) adjustable.

The parameters are valid for color light step or color light flow.

LuxSet: Set the daylight sensor threshold (10, 30, 50, 100, 150, 200, OFF).

With sufficient ambient light, the laser sensor does not turn on the light. Daylight sensor default off.

The digital value after * is current detected LUX value.

OFF delay: Set turn off light delay time

(5sec, 10sec, 15sec, 20sec, 30sec, 1min, 3min, 5min, 10min, Cancel), default 10sec.

```
OFF delay:10sec
```

System parameter setting
(page 2)

2. After finishing the setting, long press M key or wait 15s to quit parameter setting state.

Light Up/Down Test

After setting the operation parameters and system parameters, you can start up/down direction light testing by pressing the button, to verify the light output effect.

Long press M & > key for 2s, display "Light up test" on the 4 line, start up direction light testing.

Long press M & < key for 2s, display "Light down test" on the 4 line, start down direction light testing.

Match Remote Control

Long press < & > key for 2s, enter the RF remote match status, and the 4th line display "Remote match...". Immediately press the RF remote control's on/off key or zone key, when pairing is successful, the 4th line display "Remote match OK".

System Language and Recovery Factory Parameter Settings

Long press < & > key for 5s, restore factory default parameters, jump to language interface automatically, press < or > to switch two languages (Chinese and English), press M key to exit language interface.



Language interface

Installation of Laser Sensor

Size of detector:

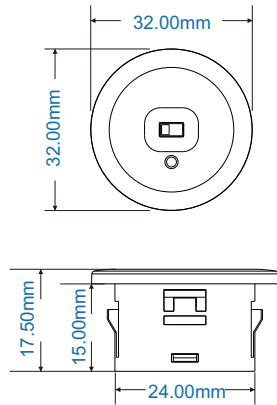

Laser sensor detection pattern:

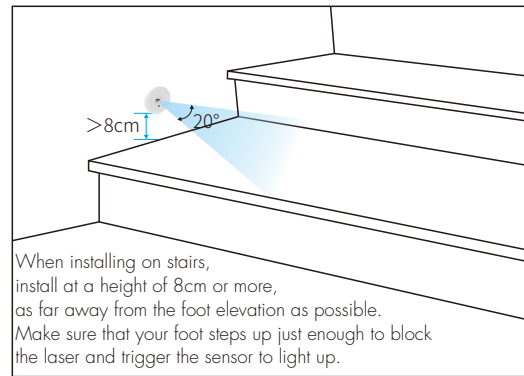

Notice for installation of laser sensor

1. The sensing head should be installed in a dry environment and keep away from windows, air conditioner and fans.
2. The sensing head should be installed in the correct direction and angle.
3. There should not be shelter(screen, furniture, large bonsai) within the range of detection.
4. Avoid touching the surface of the detector and clean the surface of the optical lens with a damp soft cloth or cotton cloth regularly to prevent dust from affecting the sensitivity.
5. This product is not fireproof, do not immerse in water or use near fire source.

Packing List



LED Controller
1 pcs

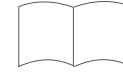

User Manual
1 pcs



Daylight sensor
(30cm)
1 pcs



ES-F
24 pcs



Laser sensor
(1m)
2 pcs



Sensor extension line
(5 m)
2pcs



ESF connection line
(11 m)
(24 interfaces)
1 pcs